

PRODUCT SPECIFICATIONS



Low Voltage Landscape Lighting Compact Well light B203 Series

Product Description

This compact well light is constructed of composite material and visor shroud cast brass cover, There is thick rubber gasket wrap the temper glass between top cover and housing of well light for a water tight seal, use the round cable and cable gland to hold to ensure water can not enter from the bottom of well light. And built with a beryllium copper socket with Mr16 led lamp. Great for application where you do not want an above ground or protruding fixture.



Product Dimension

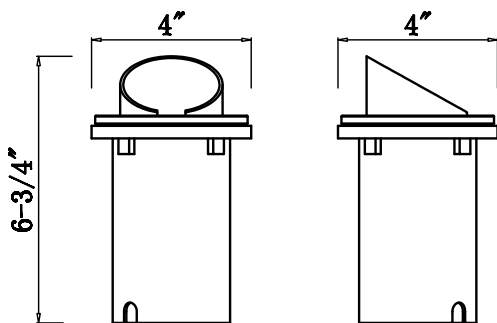

Specifications

Construction: Composite housing with cast brass shroud and has an adjustable 8° tilt socket inside.
Finish: Pre-aged Antique bronze and black powder coated
Lead Wire: 36" (standard) 18AWG, SPT-1W black waterproof wire
Glass or Lens: Clear Temper Glass Lens
Light Source (included): MR16 4W 60 degree 2700K led lamp
Maximum Lamp Rating:20W
Recommended Lamp Rating: 20W
Operating Voltage: 12V AC
Shipping Weight:1.76 lbs
Powered by: Trus-capes's Low Voltage Transformer

Features & Benefits

Composite housing with cast brass shroud and has an adjustable 8° tilt socket inside.

Pre-aged finish; powder coating for more option, paint or finish to wear off or peel—just natural patina that does not corrode.

Beryllium copper socket – more corrosion resistant than copper.

Thick rubber gasket wrap the temper glass between top cover and housing of well light for a water tight seal - keeps water from entering luminaire.

Heat resistant temper glass lens and Drainage Notch - keeps water from pooling on the face of the lens.

Dimming: Only dimmable by magnetic low voltage transformer.

Warranty

Tru-Scapes Lifetime Warranty

Certifications

