

B201 SERIES

DATA SPECIFICATION SHEET



CATEGORY: LANDSCAPE

COLORS: ● ●

PRODUCT OVERVIEW

High Power In-Ground Well Light - B201 Series

The B201 LED low voltage well light features a heavy-duty brass cap atop a black PVC ground housing, perfect for highlighting focal plants, trees, walls, statues, or fountains. With a 120° light beam, heat-resistant glass, and flush-mount design for grass, pavers, or landscapes, this well light ensures easy installation and blends seamlessly into outdoor settings. Available in black or bronze, it is fully sealed to prevent water intrusion.



Check Out All Available Colors!
Scan to Visit Our Website!

SPECIFICATIONS

- Construction: PVC pipe and solid brass gimbal and brass flat cover
- Finishes: Pre-aged Antique bronze and black powder coated
- Lead Wire: 32" (Standard) 18AWG, SPT-1W Black Waterproof Wire.
- Mounting: 8" Heavy Duty Stake with cut out for wire exit
- Light Source (included): Par36 8W 2700K 560 Lumen LED Lamp
- Glass or Lens: Clear Tempered Glass Lens
- Power Factor: 0.769
- Recommended Lamp Rating: 8W
- Operating Voltage: 12V AC
- Beam Angle: 120
- Powered By: Low Voltage Transformer (Sold Separately)

FEATURES & BENEFITS

- PVC pipe and solid brass gimbal and brass flat cover construction.
- Pre-aged finish; powder coating for more option, paint or finish to wear off or peel—just natural patina that does not corrode.
- Available in 2 different finishes, Black Powder Coat or Antique Brushed Bronze.
- Come with 32" lead with terminal connector to connect PAR36 led lamp.
- Easily replaceable lamp.
- Low energy consumption - Low Voltage LED Design.
- Heat resistant temper glass lens.
- 560 Lumen of Light Output.
- Dimming: Only dimmable by magnetic low voltage transformer.

PRODUCT DIMENSIONS

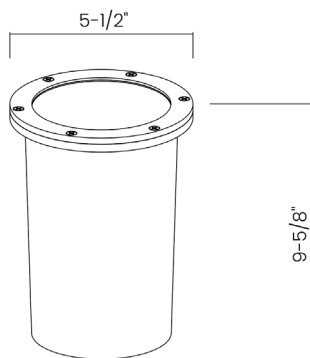

WARRANTY

- Tru-Scapes Lighting Sockets have a Lifetime Warranty.
- Light fixtures of brass, copper or stainless steel, aluminum, including finishes are warranted for five (5) years.
- LED Bulbs are warranted for five (5) years or 30,000 hours, whichever comes first.
- Stainless Steel, Painted and Weatherproof (plastic housing) transformers, excluding timers and photo cells, are warranted for five (5) years for the original purchaser.
- Tru-Scapes warranties do not cover plants that die or burn because of continuous light shined on them. This is not a defect, but the inherent nature of such plants. Certain acid loving plants such as arborvitae, pine trees, and others must not be exposed to light of any kind for more than 18 hours a day as these plants need time to sleep and allow photosynthesis to naturally occur.
- Low voltage landscape lighting fixture housings made of brass do naturally patina in color which is not a defect. (Please see www.Tru-Scapes.com for cleaning instructions.)
- See our full Warranty details at www.Tru-Scapes.com/faq.

CERTIFICATIONS



Indicates the product meets safety standards tested by Intertek.



Signifies the product has passed safety tests by Underwriters Laboratories.



Ensures the product is dust-tight and highly water-resistant.

CONTACT US

© Copyright 2024,
Tru-Scapes ® Registered Trademark •
Bucks County, PA • All Rights Reserved •
contacts@tru-scapes.com
1-800-878-1240

WWW.TRU-SCAPES.COM